



# Installation & Calibration Guide

## Monitors

# Local Exhaust Ventilation (LEV)

### Startup

The LEV monitor must be field-calibrated once installed.

#### 1. Mains powered :

- Plug in the mains adaptor and switch on the power at the main switch. **DO NOT SWITCH ON THE MONITOR!**
- Wait for 3 to 5 minutes for the pressure cell to stabilize.
- Once the stabilization period has elapsed: press and hold the on/off button to capture the duct pressure.

At the end of the calibration routine the unit will do one of two things:

- If the monitor does not detect pressure in the duct:** the sounder will chime and the Pressure Status LED will flash Red whilst the button is pressed in.
- If the monitor accepts the calibration:** the Pressure Status LED will toggle Red and Green and the Sounder will give a single beep to indicate the unit is calibrated.
- Release the on/off button.

#### 2. Battery powered :

- Press and hold the on/off button to capture the duct pressure.

At the end of the calibration routine the unit will do one of two things:

- If the monitor does not detect pressure in the duct:** the Sounder will chime and the Red LED will flash whilst the button is pressed in.

- If the monitor accepts the calibration,** the Status LED will toggle between Red and Green and then the Sounder will give a single beep to indicate the unit is calibrated.
- Release the on/off button.

### Operation - Low pressure alarm only (default)

#### 1. Mains Powered:

- If the pressure is Safe: the Green LED will be continuously illuminated.
- If the captured pressure drops more than 20%: the monitor will indicate Low Pressure Alarm, the Pressure Status LED will flash Red 3 times and the sounder will beep. The low pressure alarm will repeat every 20 seconds whilst the pressure is low. The Pressure Status LED will be illuminated permanent RED whilst it's in-between low pressure alarm cycles.
- If the pressure increases by 10%: the monitor will reset to Pressure Safe status.
- Press and hold the on/off button until the pressure status LED is off to switch off the monitor.
- Press and hold the on/off button until the pressure status LED is illuminated to switch on the monitor.



## 2. Battery Powered:

- a. When the pressure is Safe the Green LED will flash on every 70 seconds.
- b. If the captured pressure drops more than 20% the monitor will indicate Low Pressure Alarm, the Pressure Status LED will flash Red and the sounder will beep 3 times. The low pressure alarm will repeat every 70 seconds whilst the pressure is low. The Pressure Status LED will be off in-between low pressure alarm cycles.
- c. If the pressure increases by 10%: the monitor will reset to Pressure Safe status and flash on every 70 seconds.
- d. Press and hold the on/off button until the pressure status LED is off to switch off the monitor.
- e. Press and hold the on/off button until the pressure status LED is illuminated to switch on the monitor.
- f. If the battery power is low: the Low Battery alarm will chime and the Low Battery will flash until the batteries are dead or the monitor is switched off.
- g. If the battery recovers: then switching on again will cancel the Low Battery Alarm.

**Note:** The batteries are designed to last 14 months and must be replaced during annual maintenance schedules. If the monitor is constantly left in low pressure status: the battery lifespan will be reduced.

## Operation - Low & High Pressure Alarm (Optional)

The Low pressure alarm operates the same as the low pressure only alarm version.

High pressure alarm operation:

### 1. Mains Powered:

- a. When the pressure is Safe: the Green LED will be continuously illuminated.
- b. If the captured pressure increases more than 20%: the monitor will indicate High Pressure Alarm, the Pressure

Status LED will double flash Red 3 times and the sounder will beep. The high pressure alarm will repeat every 20 seconds whilst the pressure is high. The Pressure Status LED will be illuminated permanent RED whilst it's in-between high pressure alarm cycles.

- c. If the pressure decreases by 10%: the monitor will reset to Pressure Safe status.
- d. Press and hold the on/off button until the pressure status LED is off to switch off the monitor.
- e. Press and hold the on/off button until the pressure status LED is illuminated to switch on the monitor.

### 2. Battery Powered:

- a. When the pressure is Safe: the Green LED will flash on every 70 seconds.
- b. If the captured pressure increases more than 20%: the monitor will indicate High Pressure Alarm, the Pressure Status LED will double flash Red and the sounder will beep 3 times. The high pressure alarm will repeat every 70 seconds whilst the pressure is high. The Pressure Status LED will be off whilst it's in-between high pressure alarm cycles.
- c. If the pressure decreases by 10%: the monitor will reset to Pressure Safe status and flash on every 70 seconds.
- d. Press and hold the on/off button until the pressure status LED is off to switch off the monitor.
- e. Press and hold the on/off button until the pressure status LED is illuminated to switch on the monitor.
- f. If the battery power is low: the Low Battery alarm will chime and the Low Battery will flash until the batteries are dead or the monitor is switched off.
- g. If the battery recovers: then switching on again will cancel the Low Battery Alarm.

**Note:** The batteries are designed to last 14 months and must be replaced during annual maintenance schedules. If the monitor is constantly left in low pressure status: the battery lifespan will be reduced.

## LEV Monitor Dimensions

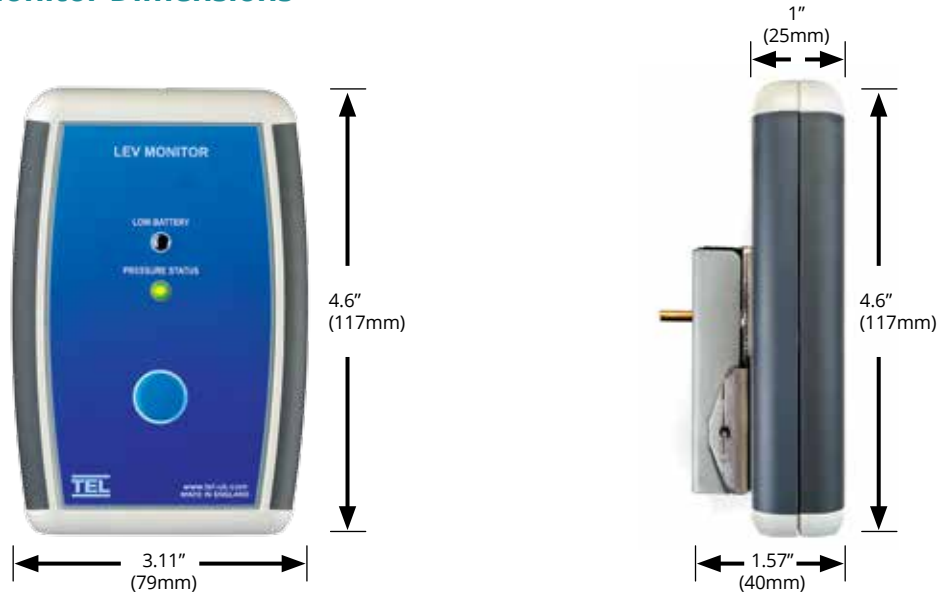

## LEV MONITOR FIXING INSTRUCTIONS

The monitor comes supplied with a duct mounting bracket. The bracket can be fixed to any round duct size over 50mm up to a flat surface.

1. Use the bracket as a template for drilling the fixing holes.
2. Fix the bracket to the duct or LEV using the 2 x No.6 self tapping screws provided. (Using the 2 x 2.5mm Holes).
3. Push the monitor onto the bracket, the monitor will be magnetically held in place.
4. Fix the monitor to the bracket using the 2 x No.4 x ½ self tapping screws provided.

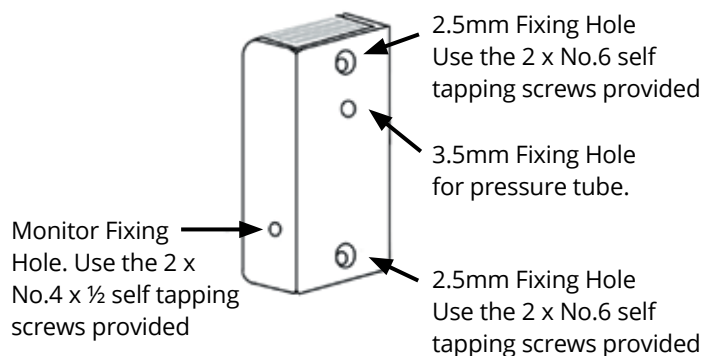

For complete manual and product information, log on to [www.tel-uk.com](http://www.tel-uk.com)